

Adjustable Digital Panel Meter 96x48mm

3 1/2-digit plus additional fixed zero ones field

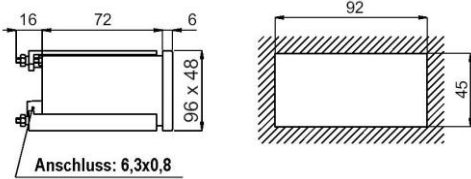

TECHNICAL DATA

3 1/2-digit digital display device with automatic polarity indication.
Shows 5 characters with fixed zero ones field.

seven-segment red LED display

digit height

h=14mm

display range

±19990

accuracy (class)

0,5 ±1 digit

frequency

40...400Hz

sampling rate

2/s

overload indication

first digit lights up

continuous overload

2In; 1,2Un

short-term overload

10In; 2Un

test voltage

2kV-50Hz-60s

operating temperature

-10...+50°C

storage temperature

-30...+70°C

auxiliary voltage

115+230V ±10% 50Hz

galvanic insulation of measurement

voltage and auxiliary voltage

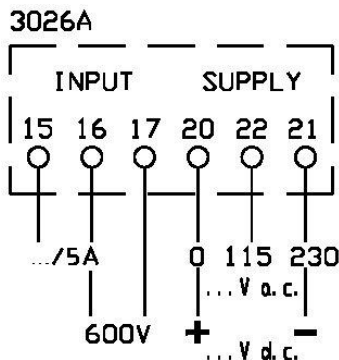
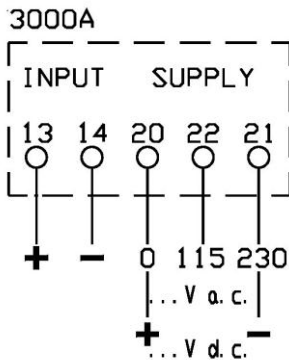

| measuring range | input resistance | Order Code |
|---|------------------|------------|
| direct voltage and direct current (d.c.) | | |
| 0-10V | ≅470kΩ | D98MV-G10 |
| shunt 60mV | ≅10kΩ | D98MA-G60 |
| 0-20mA | ≅3Ω | D98MMA-G20 |
| 4-20mA | ≅3Ω | D98MMA-G42 |

| | | |
|---|--------|---------|
| alternating voltage and alternating current (a.c.) | | |
| 0-600V | ≅4MΩ | D98EA-G |
| current transformer ..1A | ≅150mΩ | D98EA-G |
| current transformer ..1/5A | ≅30mΩ | D98EA-G |

The display range may be adjusted via DIP-switches by the customer. DIP-switches are located behind the front panel.

This digital meters show 3 1/2 floating characters plus one additional fixed zero ones field character, if needed.

The following display ranges are adjustable via DIP-switches:

| | | | | |
|-------|-------|-------|------|-------|
| 1,000 | 10,00 | 100,0 | 1000 | 10000 |
| 1,200 | 12,00 | 120,0 | 1200 | 12000 |
| 1,500 | 15,00 | 150,0 | 1500 | 15000 |
| 0,150 | 1,50 | 15,0 | 150 | 1500 |
| 1,999 | 19,99 | 199,9 | 1999 | 19990 |
| 0,200 | 2,00 | 20,0 | 200 | 2000 |
| 0,250 | 2,50 | 25,0 | 250 | 2500 |

| | | | | |
|-------|------|------|-----|------|
| 0,300 | 3,00 | 30,0 | 300 | 3000 |
| 0,400 | 4,00 | 40,0 | 400 | 4000 |
| 0,500 | 5,00 | 50,0 | 500 | 5000 |
| 0,600 | 6,00 | 60,0 | 600 | 6000 |
| 0,750 | 7,50 | 75,0 | 750 | 7500 |
| 0,800 | 8,00 | 80,0 | 800 | 8000 |

Order Information

- Order Code
- Measuring Range
- Please state custom scale printing when ordering
- DC auxiliary voltage on demand

Langer
MESSTECHNIK

Soyerhofstrasse 16
D-81547 Muenchen
Germany

☎ +49-700-LANGER-01
☎ +49-89 - 69 99 86 78
Fax +49-89 - 69 99 86 79

eMail & Internet:
info@Langer-Messtechnik.de
www.Langer-Messtechnik.de